

MASTERSPEED

DC SERVODRIVE

INDUSTRIES
MOTORS SERVO DRIVES



MASTERSPEED® (MTS)

Stand alone; four quadrant bidirectional servodrives for controlling DC Servomotors up to 15 Nm (2142.8 oz.-in.)

Typical applications are :
Medical Equipment, Milling Machines, Conveyors,
Packaging Equipment, Storage Systems,
Printing Machines, Feeders, Textile Equipment.

STANDARD FEATURES

- ✓ Internal power supply and dumping circuit
- ✓ Ventilation on board when required
- ✓ Surface Mount Tecnology
- ✓ IGBT or POWER MOSFET bridge
- ✓ Removable power module
- ✓ High industrialization
- ✓ Torque mode
- ✓ Tachogenerator feedback
- ✓ Armature feedback

OPTIONS

- ✓ Encoder feedback
- ✓ External dumping resistor (P=400, 800W)

SPECIFICATIONS

- ✓ Supply voltage range
 - (MTS60) 22÷44 VAC
 - (MTS140) 30÷95 VAC
 - (MTS200) 45÷145 VAC
- ✓ Output voltage 1.35xVAC Supply
- ✓ Input reference (differential) ±10Vdc
- ✓ Input-output demand current ±10Vdc
- ✓ Out. voltage for external use +10/-10Vdc@2.5 mA
- ✓ Enable signals +10÷30Vdc
- ✓ PWM frequency 20 KHz
- ✓ Motor current monitor ±7.5 VDC (at peak current)
- ✓ Humidity (without condensation) 10÷95 (%)
- ✓ Operating temperature 0÷40°C (32÷104°F)



DESCRIPTION

The **Masterspeed®** Servodrive comes complete with its own power supply, regenerative circuit and with detachable plug-in terminals for easy installation. The modular line makes the **Masterspeed®** the ideal solution for 1 to 3 axis applications. If required, fan cooling is incorporated into each amplifier module. Usually, the external choke isn't required.

ACCESSORIES

(see specific data sheets for details)

✓ SERVOMOTORS

- Sax 100: 0.045÷2.7Nm (6.4÷386 oz.-in.)
- Sax 350: 0.7÷1.8Nm (100÷257 oz.-in.)
- Sax 500: 2.8÷8Nm (400÷1143 oz.-in.)

✓ GEARBOXES

- Rex 100: 5 flange sizes, R ratios 1/3÷1/216

✓ TRANSFORMERS

- TM/TT: single/3ph, 100÷8000 VA

✓ NET FILTERS (for CE compliance)

- FRM/FRT: single/3ph, 2÷16 Arms

MODEL	MTS 60						MTS 140						MTS 200					
	4/8	8/16	10/20	14/28	20/40	25/50	4/8	8/16	10/20	14/28	20/40	25/50	4/8	8/16	10/20	14/28	20/40	25/50
Rated Current (Arms)	4	8	10	14	20	25	4	8	10	14	20	25	4	8	10	14	20	25
Peak Current (Arms) x 2 sec.	8	16	20	28	40*	50*	8	16	20	28	40*	50*	8	16	20	28	40*	50*
F2: Supply Line Fuses (T-type = time-lag)	4 250 V	8 A 250 V	10 A 250 V	14 A 250 V	20 A 250 V	25 A 250 V	4 A 250 V	8 A 250 V	10 A 250 V	14 A 250 V	20 A 250 V	25 A 250 V	4 A 250 V	8 A 250 V	10 A 250 V	14 A 250 V	20 A 250 V	25 A 250 V
Supply (VAC) (3PH)	44 VAC ^						95 VAC ^						145 VAC ^					

^: Recommended AC power supply

*: Peak current= x 1 second

Drawings are not to scale (see quotations)

MECHANICAL DIMENSIONS

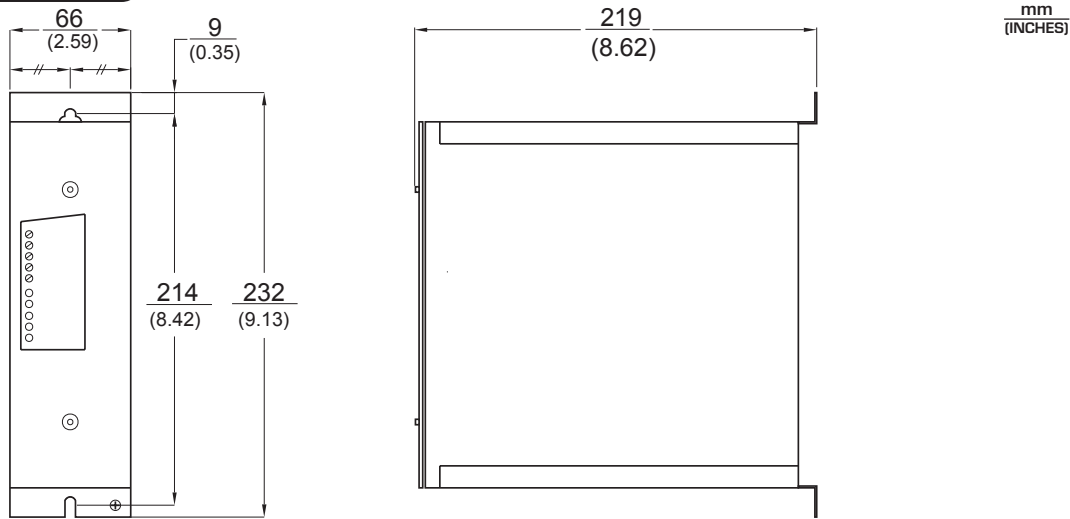

Weight: 2.7 Kg

CONNECTION DIAGRAM

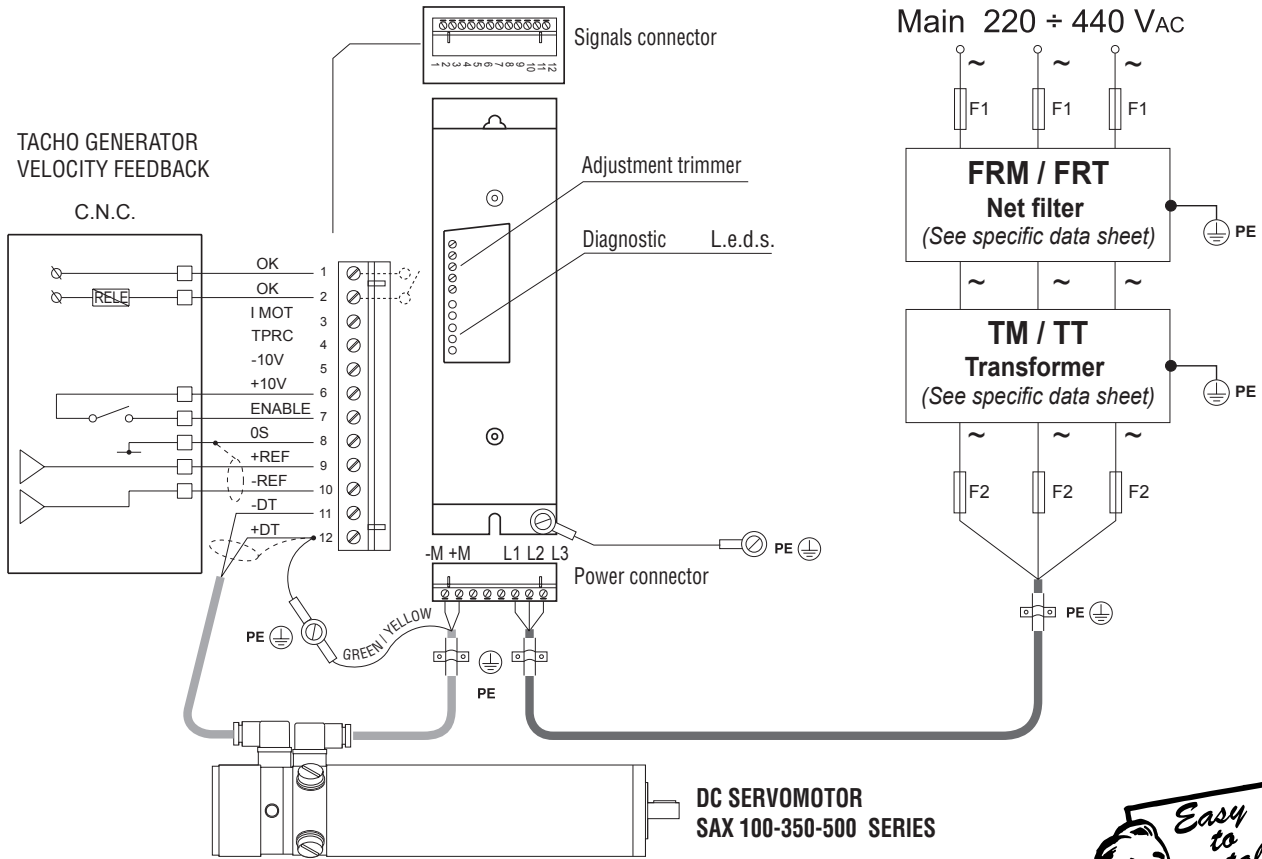

ORDERING CODE
Example:

MTS - 200 - 10 / 20 - RX - S - 1000 / T0 - RD

NAME: Dc Servodrive

AMPLIFIER TYPE: 060 - 140 - 200

SIZE: 04/08 - 08/16 - 10/20 - 14/28 - 20/40 - 25/50

DUMPING SIZE:

- RX = internal standard resistors
- R4 = 400W external resistors (optional)
- R8 = 800W external resistors (optional)

PROTECTION:
S = Standard
T = Tropicalized

adjustment identification number

CONTROL MODE:
RD = Differential reference
IO = Demand Current (torque mode)
PD = PWM+DIR (optional)

FEEDBACK:
T0 = Tachogenerator (DC)
A0 = Armature
E0 = Encoder (optional)
00 = No feedback adjustment (for IO and PD control modes)