

FEATURES

- ◆ Special anti-backlash worm & gear set, providing 50:1 reduction
- ◆ Moderate load capacity (up to 50 lbs vertical load)
- ◆ Sealed against dust and contaminants
- ◆ Includes precision inductive proximity HOME sensor
- ◆ All models with stepper motor option feature 125 oz • in stepper motor, model KO4322P695252
- ◆ All models with servo motor option feature model K72U32-2464 with 1000 line driver optical rotary encoder.
- ◆ Versatile mounting surfaces
- ◆ Sturdy single piece aluminum case
- ◆ Heavy-duty chrome plated steel table top with integral shaft
- ◆ Includes 4 tapped 1/4-20 x 3/8" holes for mounting

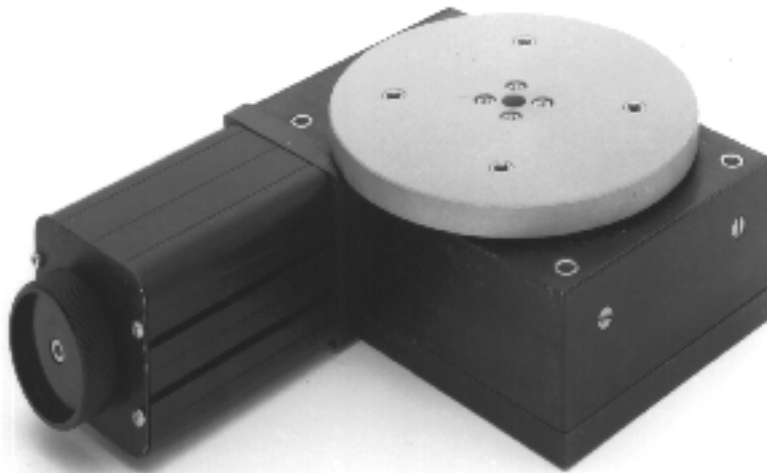

CATALOG NUMBER	
KV5822P37012WV	Stepper Servo
KV5822P37012VY	

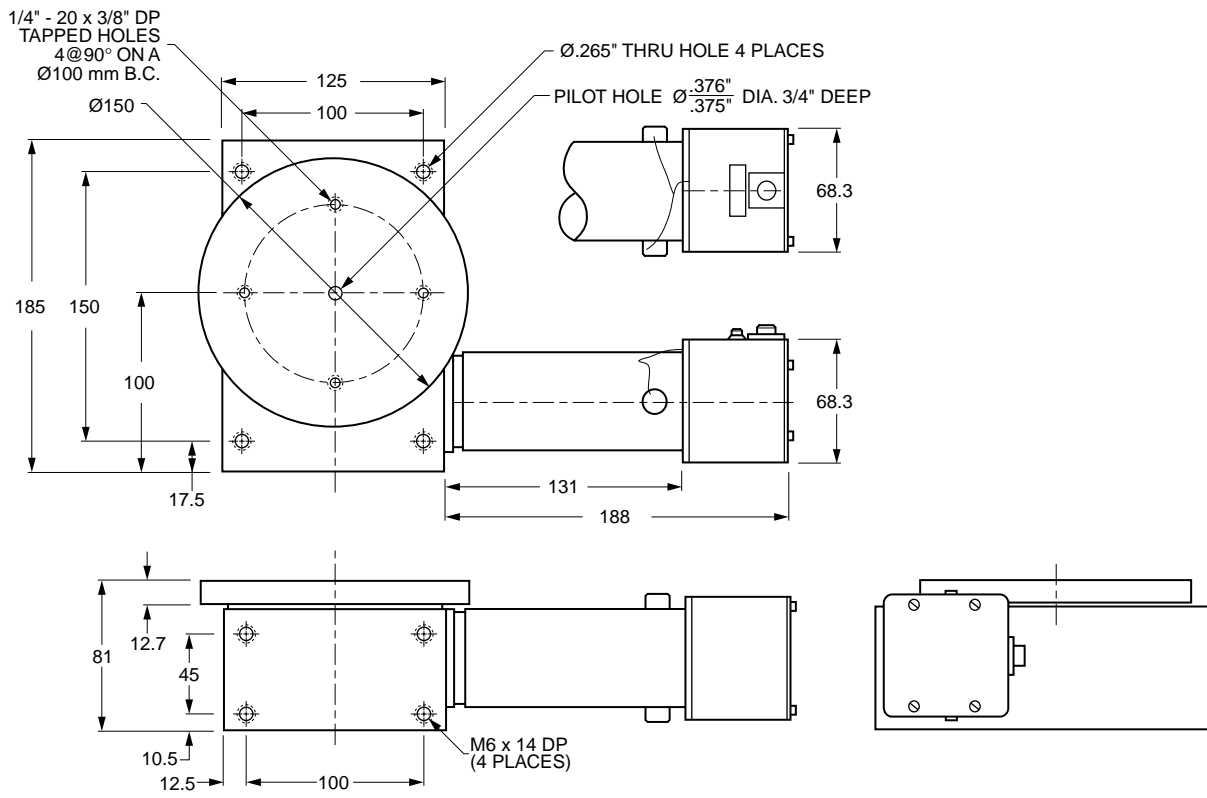

SPECIFICATIONS	Stepper	Servo
Table Diameter	150 mm	
Table Height	81 mm	
Table Center Height	100 mm	
Center Hole, Diameter	Ø.375 in.	
Center Hole, Depth	.75 in.	
Maximum Speed	90 deg / sec	135 deg / sec
Resolution	.009°	.0018°
Maximum Torque	50 lb•in	
Load Capacity, Horizontal	50 lb / in	
Load Capacity, Vertical	23 kg (50 lbs)	
Clamping Torque	50 lb•in	
Homing Accuracy	.038°	
Repeatability	.038°	
Flatness	.001" TIR	
Concentricity	.0015" TIR	
Weight	4 kg (8.8 lbs)	4.5 kg (9.9 lbs)

NOTES ON SPECIFICATIONS: Stepper motor is model KO4322P695262, operating in half step mode, with 4.5A / phase, 40V chopper driver.
 Servomotor is model K72U32-2464, operating with 6A/80V chopper amplifier and 1000-line encoder operating in quadrature.
 These figures will, of course, vary with different loads, amplifiers and acceleration profiles provided by the controller.